

TOUCH PANEL CONTROLLER**Delivery Specification****Model Name: AHL-71N**

* The contents of specifications are subject to change without prior notice for product improvements.

The export of this product from Japan is regulated by the Japanese government. The export of this product may be prohibited without governmental license. To export or re-export of this product from a country other than Japan may also be prohibited without a license from that country. Please call a GUNZE LIMITED sales representative.

GUNZE LIMITED**ELECTRONIC COMPONENTS DIVISION**

Electronic Components Division: 10, Shindo, Amarube-cho,
Kameoka city, Kyoto (621-0806), Japan
Osaka Sales Section: Hanahara 6th Building, 6-8-31, Nishinakajima,
Yodogawa-ku, Osaka (532-0011), Japan
TEL +81-6-6303-6220
Tokyo Sales Section: GUNZE Nihonbashi Building, 2-10-4, Nihonbashi,
Chuoh-ku, Tokyo (103-0027), Japan
TEL +81-3-3276-8717

Approved by: _____

Checked by: _____

Staff Responsible: _____

Date of Revision	Indication for Revision	Revised Contents	Remarks	Checked by

Precautions

1. Avoid using this panel for applications that may affect people's lives, such as medical equipment, space equipment, aircraft, submarine repeater and other equipment for which extremely high reliability is required.

2. If you are planning to use this panel for control or security system in transport equipment (train, automobile and vessel or the like), always contact our sales service center in advance. The quality level of this product is limited to general applications. (Computer, OA equipment, FA equipment, communication equipment, measuring equipment, AV equipment, etc.)

3. Do not ever remodel or recompose our products. It may cause problems and breakdown.

* The copy right of this specification belongs to GUNZE LIMITED, and all rights are reserved.

* The contents of this specification may be changed without notice.

* Trademarks in this specification:

PC/AT is a registered trademark of International Business Machine Corporation(IBM).

Windows XP, Windows 2000 and Windows Me are registered trademarks of U.S. Microsoft company.

The others, company's name and product's name, are also registered trademarks of each company.

CONTENTS

1. Outline	6
2. Features	6
(1) Lead-free products	6
(2) Power supply	6
(3) Clock frequency	6
(4) Electrical resolution	6
(5) Output Signal Transmission	6
(6) Output rate	6
(7) Output mode	6
(8) Applicable touch panel	6
(9) External shape	6
3. Terminal Arrangement Drawing	7
4. Terminal Function	7
5. Electrical Characteristics.....	8
(1) Absolute maximum rating	8
(2) DC Characteristics	8
(3) AC specifications	9
(4) Clock timing specifications	9
(5) 10-Bit A/D converter Characteristics(ANIN1 ~ ANIN4)	10
6.Touch panel input timing	10
7. Setting	11
(1) Outline	11
(2) Setting	11
8. Output Mode	11
9. Serial Interface	12
(1) Outline	12
(2) Communication format	12
(3) Text format	12
(4) Response speed	12
(5) Output rate	13
(6) Command System	13
(7) Output pattern when the transmission stop and transmission restart commands were received	14
10. Other function	15
(1) Calibration	15
(2) Stop mode	16
(3) Watch dog reset	16
11. Outline Drawing	17
12. Peripheral Circuit Example.....	18
13. Soldering Conditions.....	19

14. Reliability	20
15. Packing Condition	21
16. Packing Method	21
17. Operating Precautions	24
18. Warranty Period and Warranty Range.....	24
(1) Warranty period	24
(2) Warranty range	24
19. Appendix.....	25
Difference between 4- and 8-wire touch panels	25

1. Outline

The AHL-71N is a product with lead-free. The good point supports lead-free solder as well as not containing lead in a product. Therefore this will be suitable for a customer think about an environmental consideration. The AHL-71N is a substitute for the AHL-71 without quite losing a function.

The AHL-71N is a controller to detect the touching position on the touch panel. Even if an unstable data (voltage value) generated when the touch panel was lightly depressed and noise arising due to operating environment are inputted to the AHL-71N, internal filtering (firmware) is carried out; it is, therefore, possible to detect the pushing pressure position with high precision.

The communication system contains serial (start-stop). Where the serial interface is used, direct connection to the COM port of a personal computer is possible by connecting the EIA-232D (RS-232C) transceiver. For the circuit in the touch panel driving part among the AHL-71N peripheral circuits, use the GUNZE recommendable circuit. (Refer to "12. Peripheral Circuit Example".)

2. Features

(1) Lead-free products

This products fit to solder by lead-free.(Can not solder by traditional Sn-Pb solder.)

(2) Power supply

2.7 to 5.5V

(3) Clock frequency

4.9152MHz

(4) Electrical resolution

10 bits (1,024 × 1,024)

NOTE) This numerical value is the electrical resolution of AHL-71N. The electrical resolution in the touch panel key area is lower than this numerical value, which differs among the touch panels.

(5) Output Signal Transmission

- Serial Transmission (RS-232C)

(6) Output rate

- 87 cps (Co-ordinate Per Second)

NOTE) Under the following communication conditions:

Communication speed	:	9,600 bps
Parity	:	None
Data length	:	8 bits
Stop bit length	:	1 bit

(7) Output mode

- Continuous (The coordinate data is transmitted while the touch panel is being touched.)

(8) Applicable touch panel

- GUNZE's 4- & 8-wire conductive layer type analog touch panel

(9) External shape

30-pin SSOP (9.85 × 8.1 × 1.3 mm) (MAX.)

3. Terminal Arrangement Drawing

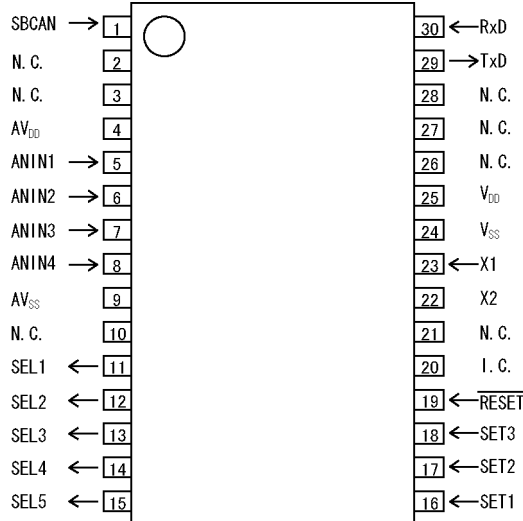

4. Terminal Function

Pin No.	Terminal Name	Input/Output	Function	Pin No.	Terminal Name	Input/Output	Function
1	SBCAN	Input	Stop Mode Release Input Terminal	19	~RESET	Input	Reset Input Terminal
4	AVDD	-	Power Supply Terminal for A/D Converter connected to VDD	20	I.C.	-	Connecting to VSS
5	ANIN 1	Input	Analog Input Terminal 1 for Touch-panel Pushed Position Data (10bit)	22	X2	-	Quartz Oscillation Terminal (Output)
6	ANIN 2	Input	Analog Input Terminal 2 for Touch-panel Pushed Position Data (10bit)	23	X1	Input	Quartz Oscillation Terminal (Input)
7	ANIN 3	Input	Analog Input Terminal 3 for Touch-panel Pushed Position Data (10bit)	24	VSS	-	GND
8	ANIN 4	Input	Analog Input Terminal 4 for Touch-panel Pushed Position Data (10bit)	25	VDD	-	Power
9	AVSS	-	GND Terminal for A/D Converter connecting to VSS	29	TxD	Output	Serial Data Output Terminal
11	SEL 1	Output	Touch-panel Control Terminal 1	30	RxD	Input	Serial Data Input Terminal
12	SEL 2	Output	Touch-panel Control Terminal 2	2,3,10,21,26,27,28	N.C.	-	
13	SEL 3	Output	Touch-panel Control Terminal 3				
14	SEL 4	Output	Touch-panel Control Terminal 4				
15	SEL 5	Output	Touch-panel Control Terminal 5				
16	SET 1	Input	Baud Rate (bps) Setup Terminal				
17	SET 2	-	Don't use(By all means open Terminal)				
18	SET 3	Input	Stop mode Control				

5. Electrical Characteristics

(1) Absolute maximum rating

Parameter	Symbol	Ratings	Unit
Supply voltage	VDD	-0.3 – 6.5	V
Input voltage	VI	-0.3 - VDD+0.3	V
Output voltage	VO	-0.3 - VDD+0.3	V
Operating ambient temperature	Topr	-40 - 85	°C
Storage temperature	Tstg	-65 - 150	°C

NOTE) Where the unit was used with the absolute maximum rating exceeded, permanent breakdown may be caused to the AHL-71N. In normal operation, it is desirable to use this unit under the recommendable operation conditions, and if these conditions are exceeded, AHL-71N reliability will be adversely affected.

(2) DC Characteristics

(Unless otherwise specified ; VDD=2.7 - 5.5V, VSS=0V, Ta=-40 - 85°C)

Parameter	Symbol	Test Conditions	Min.	Typ.	Max.	Unit	Remarks
Output "L" Current	I _{OL}	1port			10	mA	SEL5, TxD
		Port Total			80	mA	
Output "H" Current	I _{OH}	1port			-1	mA	SEL1 ~ 5, TxD
		Port Total			-15	mA	
Output "H" Voltage	V _{OH}	I _{OH} =-1mA V _{DD} =4.5 ~ 5.5V	V _{DD} -1.0			V	SEL1 ~ 5, ¹ TxD
		I _{OH} =-100μA V _{DD} =2.7 ~ 5.5V	V _{DD} -0.5			V	
Output "L" Voltage	V _{OL}	I _{OL} =10mA V _{DD} =4.0 ~ 5.5V			1.0	V	SEL1 ~ 5, TxD
		I _{OL} =400μA V _{DD} =2.7 ~ 5.5V			0.5	V	
Input "H" Voltage	V _{IH}		0.7V _{DD}		V _{DD}	V	SET1 , 3
			0.8V _{DD}		V _{DD}	V	~RESET,SBCAN,RxD
			V _{DD} -0.1		V _{DD}	V	X ₁ ,X ₂
		V _{DD} =4.5 ~ 5.5V	V _{DD} -0.5		V _{DD}	V	
Input "L" Voltage	V _{IL}		0		0.3V _{DD}	V	SET1 , 3
			0		0.2V _{DD}	V	~RESET,SBCAN,RxD
			0		0.1	V	X ₁ ,X ₂
		V _{DD} =4.5 ~ 5.5V	0		0.4	V	
Input "H" Current	I _{IH}	V _I =V _{DD}			3.0	μA	RxD,SET1 , 3,SBCAN
					20	μA	X ₁ ,X ₂
Input "L" Current	I _{IL}	V _I =V _{SS}			-3.0	μA	RxD,SET1 , 3,SBCAN
					-20	μA	X ₁ ,X ₂
Pull up Resistor	R _P		10	30	60	kΩ	SEL1 ~ 4
		V _{IN} =0V	50	100	200	kΩ	SEL1 ~ 3
Supply Current	I _{DD}	V _{DD} =5V±10%		1.1	2.0	mA	
		V _{DD} =3V±10%		0.3	0.45	mA	
		When in A/D conversion V _{DD} =5V±10%		1.7	3.1	mA	
		When in Stop Mode V _{DD} =5V±10%		0.1	10.0	μA	
		When in Stop Mode V _{DD} =3V±10%		0.05	5.0	μA	

*1:Output of SEL1,SEL3 are defined as non connect. But in fact, they will be low value by inner pull up resistor or connected transistor.

(3) AC specifications

(Unless otherwise specified; VDD=2.7 ~ 5.5V, VSS=0V, Ta=-40 ~ 85°C)

Parameter	Symbol	Conditions	Min.	Typ.	Max.	Unit
Reset input "L" pulse width	tW(~RESET)		10			μs
SBCAN input "H" pulse width	tWH(SBCAN)	VDD=4.1 ~ 5.5V	10			ns

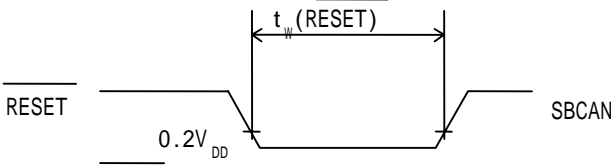

Fig.1 RESET Input Timing

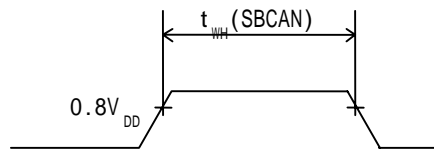

Fig.2 SBCAN Input Timing

(4) Clock timing specifications

(Unless otherwise specified; VDD=2.7 ~ 5.5V, VSS=0V, Ta=-40 ~ 85°C)

Parameter	Symbol	Conditions	Min.	Typ.	Max.	Unit
Oscillator Frequency	fx			4.9152		MHz
Oscillation stable time (Ceramic oscillator)		After VDD has reached at min. voltage			4	ms
Oscillation stable time (Crystal Oscillator)		VDD=4.5 to 5.5V			10	ms
Cyclic time for external clock	tC(X1IN)			203		ns
X1 Input "H", "L" width (tXH, tXL)			87		102	ns

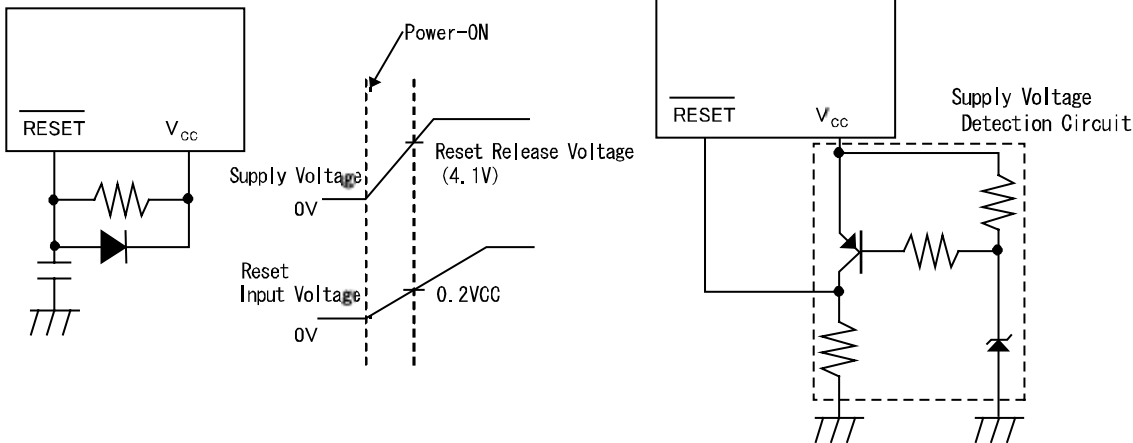

Fig.1. Reset Circuit Example

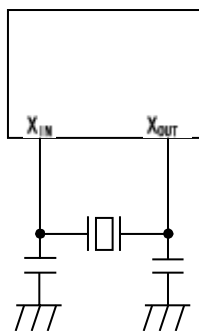

Fig.2 Circuit
Crystal(Cera
Oscillator)

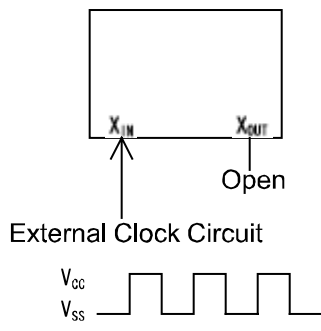

Fig.3 External Clock
Input Circuit

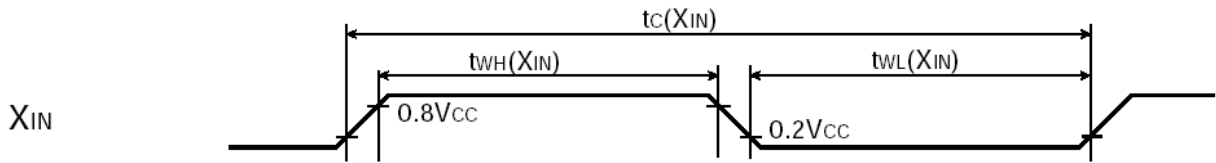

Fig.4 XIN Input Timing

(5) 10-Bit A/D converter Characteristics(ANIN1 ~ ANIN4)
(TA=-40 ~ 85 ,AVDD=VDD=2.7 ~ 5.5V,AVSS=VSS=0V)

Parameter	Symbol	Conditions	Min.	Typ.	Max.	Unit
Resolution			10	10	10	bit
Overall error ^{*1,2}		4.5V V _{DD} 5.5V		± 0.2	± 0.4	%FSR
		2.7V V _{DD} 5.5V		± 0.4	± 0.6	%FSR
Conversion time	t _{CONV}		14		100	μs
Zero-scale error ^{*1,2}		4.5V V _{DD} 5.5V			± 0.4	%FSR
		2.7V V _{DD} 5.5V			± 0.6	%FSR
Full-scale error ^{*1,2}		4.5V V _{DD} 5.5V			± 0.4	%FSR
		2.7V V _{DD} 5.5V			± 0.6	%FSR
Non-integral linearity error ^{*1,2}	INL	4.5V V _{DD} 5.5V			± 2.5	%FSR
		2.7V V _{DD} 5.5V			± 4.5	%FSR
Non-differential linearity error ^{*1,2}	DNL	4.5V V _{DD} 5.5V			± 1.5	%FSR
		2.7V V _{DD} 5.5V			± 2.0	%FSR
Analog input voltage	V _{IAN}		0		AV _{DD}	V

*1:Excludes quantization error(± 0.05%).

*2:It is indicated as a ratio to the full-scale value(%FSR).

6.Touch panel input timing

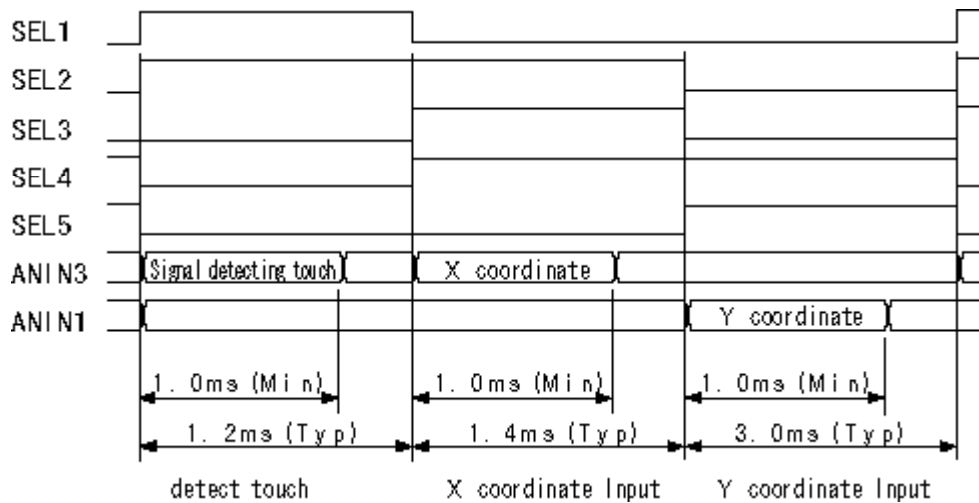

It is movement during touch. When it is a non-touch ,AHL-71N repeatedly detects touch.

7. Setting

(1) Outline

Interface setting is the following 2 type. It is possible that the specified terminal of AHL-71N can be open or connected with VSS.

- (a) Baud Rate (bps)
- (b) Stop Mode

(2) Setting

(a) Baud Rate (bps)

SET1	Baud Rate
VSS	19200bps
Open	9600bps

(b) Stop Mode

SET3	Stop Mode
VSS	Valid
Open	Invalid

8. Output Mode

○ Continuous mode

The positional data is continuously outputted while the touch panel is being touched. When your finger or pen was released from the touch panel, only one data in the release position is outputted. When it is not touched, no data is outputted.

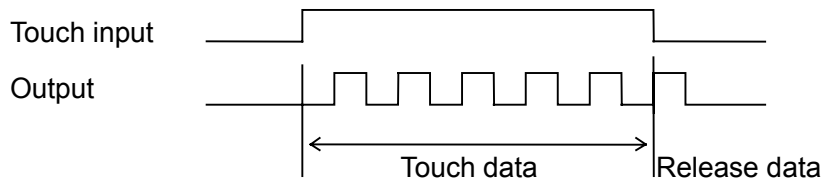

9. Serial Interface

(1) Outline

Using start-stop serial, touch position data and command communication can be carried out.

By connecting EIA-232D (RS-323C) transceiver, direct connection to the COM port of a personal computer, etc. is possible. Also available is the device driver for mouse emulation. By using this unit, the touch panel can be used in place of the mouse.

device driver list

product name	Applied OS
U-TP	WindowsNT4.0
TPDD	WindowsMe,Windows2000,WindowsXP

(2) Communication format

- Communication speed : 9600 / 19200 bps
- Data length: 8 bits
- Parity: None
- Stop bit: 1 bit

(3) Text format

- According to 8-bit ASCII format, one data is transmitted at 11 bytes.

HEADER ('T'/'R')	X Coordinate (4 bytes)	',' (2Ch)	Y Coordinate (4 bytes)	CR (0Dh)	LF (0Ah)*
-----------------------	-----------------------------	-------------	-----------------------------	------------	-------------

* Where "CR" + "LF" was set as a delimiter:

NOTE) The delimiter default is only "CR".

- o Example in Continuous Mode:

```

T0273,0581 ← When the touch panel was depressed
T0273,0582
T0272,0581
.
.
.
.
.
T0273,0582
R0273,0581 ← The touch panel was released.
    
```

- * The data while the touch panel is being depressed is transmitted with "T" prefixed as a header, and when the touch panel was released, only one data is transmitted with "R" prefixed as a header.
- * The data is the numeral of 0 to 1,023 (decimal) for both X and Y.
- * Where the AHL-71N and touch panel were connected as specified, the touch panel left lower part becomes the origin.

NOTE) Even when the touch panel left lower part is depressed, the data of (0, 0) is not outputted. Also, even the touch panel right upper part is depressed, the data of (1023, 1023) is not outputted. Actually, 0 to 1023 inside data are outputted. (Example: 20 to 1000)

(4) Response speed

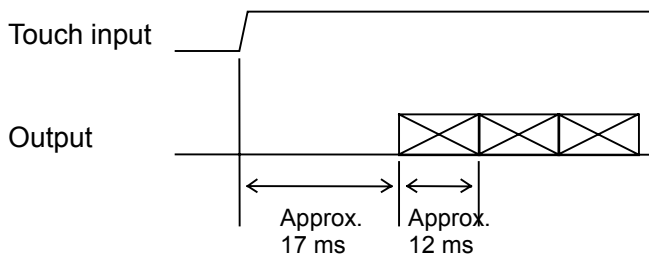

NOTE) The communication conditions are as follows for the data.

Communication speed	: 9600
bps	
Parity	: None
Data length	: 8 bits
Stop bit	: 1 bit

(5) Output rate

- Approx. 87 cps (cps: Co-ordinate Per Second)

NOTE) The communication conditions are as follows for the data.

Communication speed : 9600 bps
 Parity : None
 Data length : 8 bits
 Stop bit : 1 bit

(6) Command System

Command	Operation
RE	Resets the AHL-71N. However, if this command is received during data transmission, the data being transmitted may be in disorder.
DI	Diagnosis of the AHL-71N. In the normal condition, "Pass ____" is returned. * " " means the space.
SR	Transmission stop. The command is accepted, however. During data transmission, the transmission is stopped from the next data.
BR	Transmission re-start
CTRL+S (XOFF)	(Same as "SR" command)
CTRL+Q (XON)	(Same as "BR" command)
VE	Returns software version "Vn.nn_". * " " means the space.
LF	The data delimiter should be "CR(0Dh)" + "LF (0Ah)".
CR	The data delimiter should be "CR (0Dh)".
XL	Returns the reference data on the X-coordinate low voltage side. The reference data refers to the data in the touch panel electrode part.
XH	Returns the reference data on X-coordinate high-voltage side.
YL	Returns the reference data on Y-coordinate low-voltage side.
YH	Returns the reference data on Y-coordinate high-voltage side.

- NOTES) 1) Transmit the command in the ASCII format.
 2) When transmitting the command, send "CR" (0Dh) lastly (as a delimiter).
 3) Any letter, capital or small, is effective for the command.
 4) The command is executed immediately upon receipt thereof. The command is accepted even when the AHL-71N is being transmitted, and for the command with response data, such as "DI" and "VE" commands, the response data is outputted in the course of position data, and then, the position data is outputted again.

(Example) "DI" command

```

:
:
T0381,0892
T0381,0892
T0380,0892
Pass
T0380,0893
T0381,0892
:
:
    
```

- 5) For the response data to the command, normally, transmit "CR" (0Dh) lastly (as a delimiter).
 6) Where the command could not be received normally or the command that is not present in the list was sent, it is disregarded. (No data is outputted.)
 7) The interval between commands should be 15 ms or more.

(7) Output pattern when the transmission stop and transmission restart commands were received

<Pattern 1>

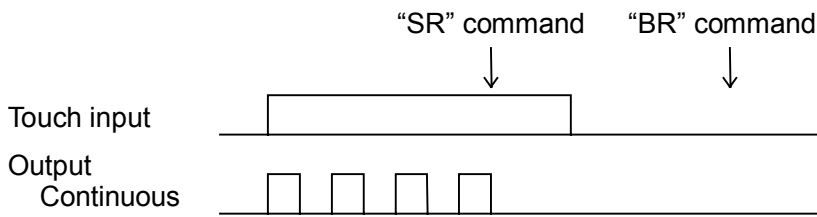

<Pattern 2>

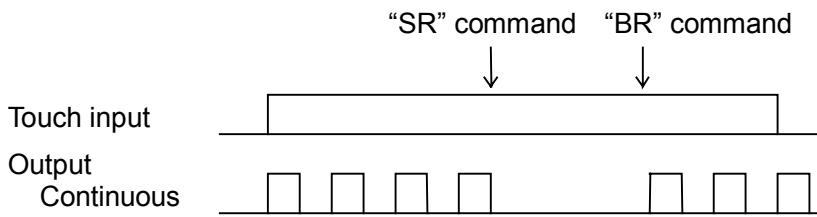

<Pattern 3>

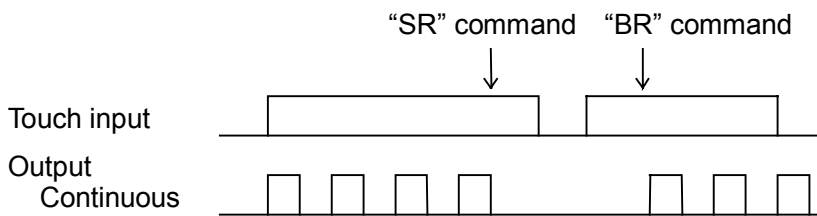

* Each pulse of output is one-point data.

10. Other function

(1) Calibration

(a) Auto calibration

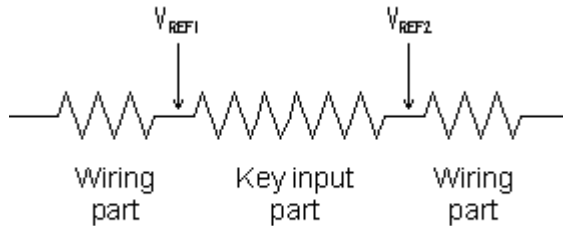

Touch Panel Equivalent Circuit

Since the touch panel forms the equivalent circuit as shown in the figure above, if direct current voltage is applied to both ends of the touch panel, some dc voltage will be applied to the key input part, and the remaining one will be applied to the wiring part. Consequently, if the resistance value of only key input part and only wiring part changes, the voltage applied thereto also changes. In other words, if the resistance value in each part of the touch panel changes, the output voltage when the same point on the touch panel was depressed differs, thereby giving rise to a phenomenon of positional deviation.

On the other hand, in combinations of (AHL-71N) + (8-wire touch panel), the AHL-71N checks double-end voltage (reference voltage: V_{REF1} , V_{REF2}) in the key input part of the touch panel in order to make internal correction so that the data on the low voltage side becomes zero and the high-voltage side data becomes "1023" or "4095" which is referred to as auto calibration; therefore, there is virtually no positional deviation caused by changes in resistance value in each part of the touch panel.

The reference voltage is saved inside the AHL-71N.

The AHL-71N checks the reference voltage when; 1. the power is turned ON; and 2. the unit is reset.

- * Normally, the touch panel reference data does not change significantly as shown in the example above. Accordingly, the reference data is not rewritten substantially, either.
- * In our touch panel, the resistance value in each part is hard to change, but it may vary, depending on operating conditions (environment) or when it has been used over a long period of time.

(b) User calibration

In the touch panel module in which the touch panel and display were laminated, the touch panel pressing position and display position must be aligned with each other. This is called "user calibration".

This user calibration should be carried out when the touch panel module is used for the first time, and the touch panel pressing position and display position shifted, for example.

(NOTE) There is no correlation between the touch panel pressing position and display position with the touch panel module assembled. It is, therefore, necessary to always carry out user calibration the first time the touch panel module is used. Even when the touch panel module is of the same configuration, the position data in the same point of the touch panel differs among the modules for reasons of dispersion in touch panel resistance value, etc. Also, there is a need to carry out user calibration for each module even if the touch panel module is of the same configuration since there is an error in touch panel and display lamination as well, for example.

As one example of user calibration method, a description is given of the method used by pressing 2 points on the touch panel.

* Position data of touch panel at point A: (X_A, Y_A)

* Position data of touch panel at point B: (X_B, Y_B)

However, $X_A < X_B$ and $Y_A < Y_B$.

* Dot position on the display at point A: (DX_A, DY_A)

* Dot position on the display at point B: (DX_B, DY_B)

However, $DX_A < DX_B$ and $DY_A > DY_B$.

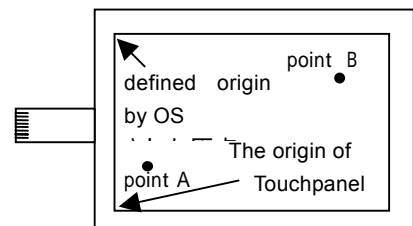

The number of dots (DX1) per data in the X direction is:

$$DX1 = (DX_B - DX_A) / (X_B - X_A) \text{ A)}$$

The number of dots (DY1) per data in the Y direction is:

$$DY1 = (DY_A - DY_B) / (Y_B - Y_A) \text{_____ B)}$$

Therefore, the relationship between the optional positions (X_D, Y_D) on the touch panel and dot positions (DX_D, DY_D) on the display is:

$$DX_D = DX_A - DX1 \times (X_D - X_A) \text{_____ C)}$$

$$DY_D = DY_A - DY1 \times (Y_D - Y_A) \text{_____ D)}$$

Attention! Screen the left top usually becomes the origin by the OS such as Windows, but touch panel defines the left bottom as the origin. Therefore calculation type of DY_D is different from DX_D .

Explanation is given below of the above calibration method.

- 1) Press 2 points on the display to obtain the data of X_A, Y_A, X_B & Y_B . Save these data in the host computer.
- 2) From eq. A) and eq. B) above, find $DX1$ and $DY1$. Save this data and DX_A & DY_A as well in the host computer.

This completes the user calibration. During normal operation, find the touch positions DX_D, DY_D on the display unit from these data and position data X_D, Y_D when the touch panel was depressed, using eq. C) and eq. D) above. This calculation should be made each time the touch panel position data is inputted.

Thus, the touch positions DX_D, DY_D on the display are found according to the touch panel position data X_D, Y_D .

(2) Stop mode

Stop Mode is a low power consumption mode that AHL-71N is providing.

When in Stop Mode, the program stops temporary and ensures the system lower power consumption.

i. When to become Stop Mode?

In the condition Pin No.18 (SET3, Stop Mode Control) connected to Pin No.24 (VSS, GND).

when the touch panel is not pushed for more than 30 seconds, and also, command is not fed either at serial transmission.

ii. How to alter Stop Mode?

- 1) Reset AHL-71N.
- 2) Feed Start Edge to SBCAN terminal (Pin No.1).

*In case the relative circuit is designed same as our recommendation (see Sec.12), the panel touching produces a feeding Start Edge. So, the panel touching alter Stop Mode.

iii. How to avoid Stop Mode?

- 1) Opening Pin No.18 (Stop mode Control) can avoid Stop Mode absolutely.
- 2) In the case Pin No.18 connected to Vss, at serial transmission, send a command once in 29 seconds period.

* If command is sent, it will not go to Stop Mode for 30 seconds.

(3) Watch dog reset

AHL-71N provides automatic reset function in the event software goes nowhere other than aimless running, of which cause may be like some environmental condition.

11. Outline Drawing

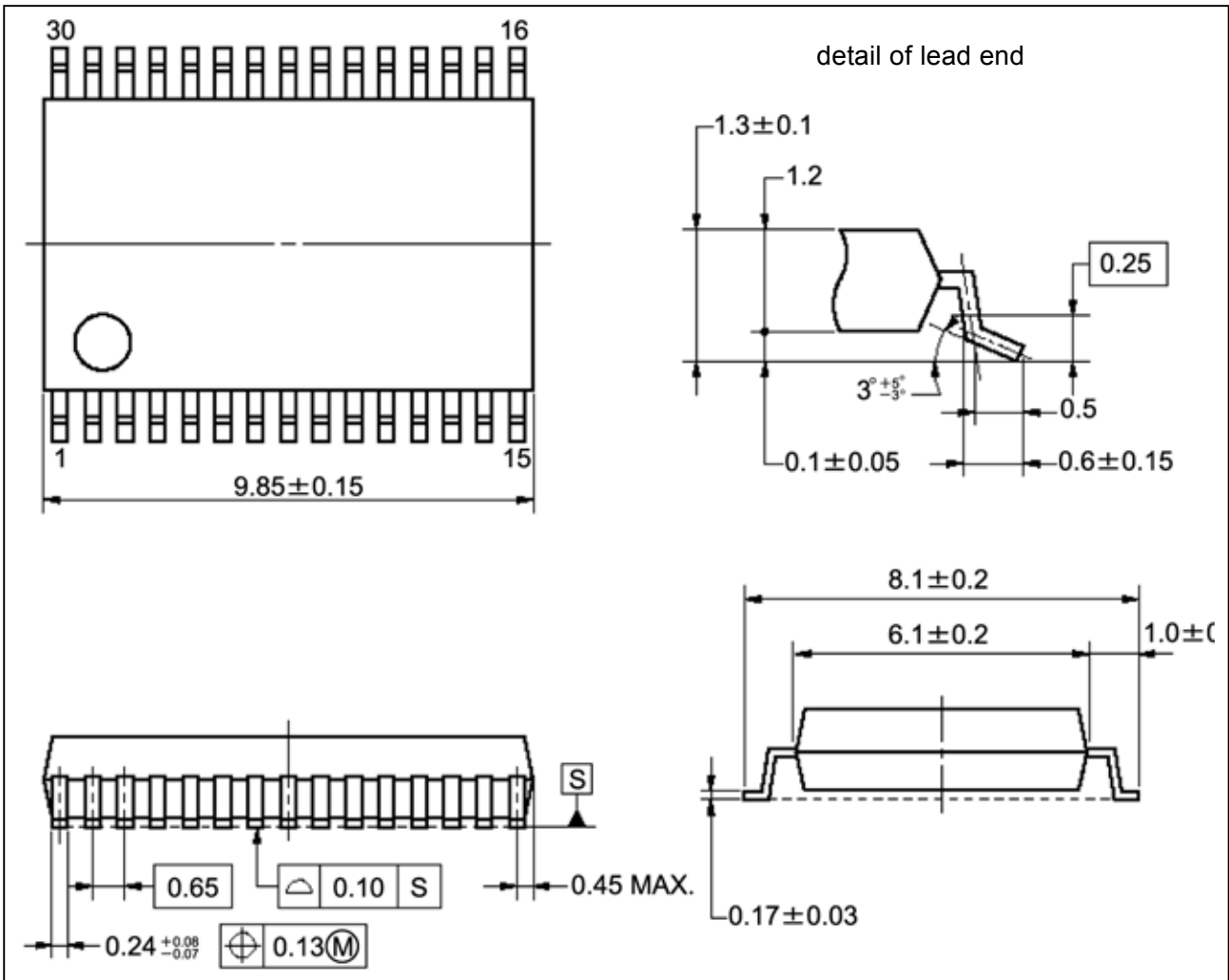

NOTE

Each lead centerline is located within 0.13mm of its true position (T.P.) at maximum material condition.

12. Peripheral Circuit Example

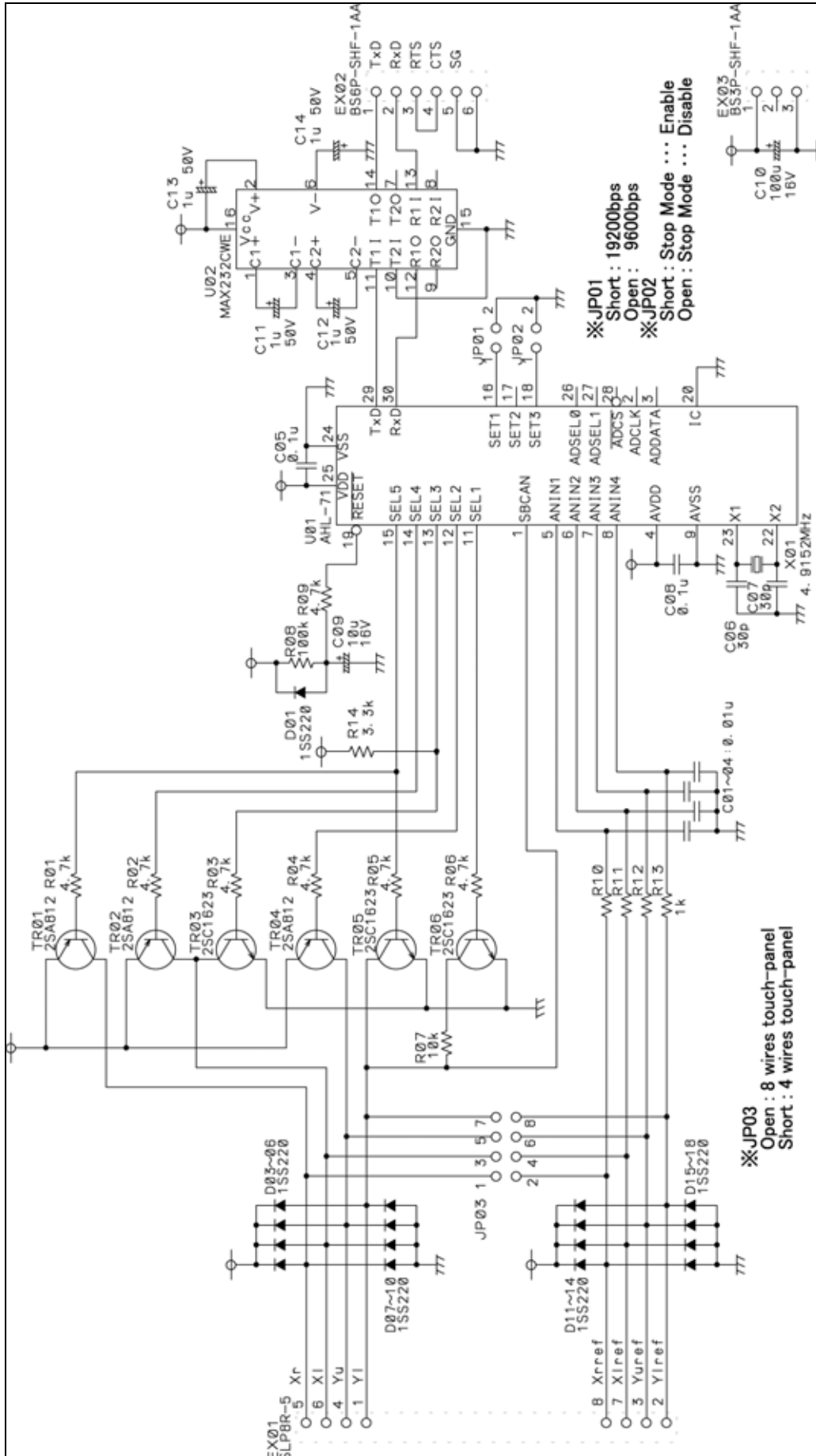

13. Soldering Conditions

The following is recommended soldering conditions of infrared reflow.

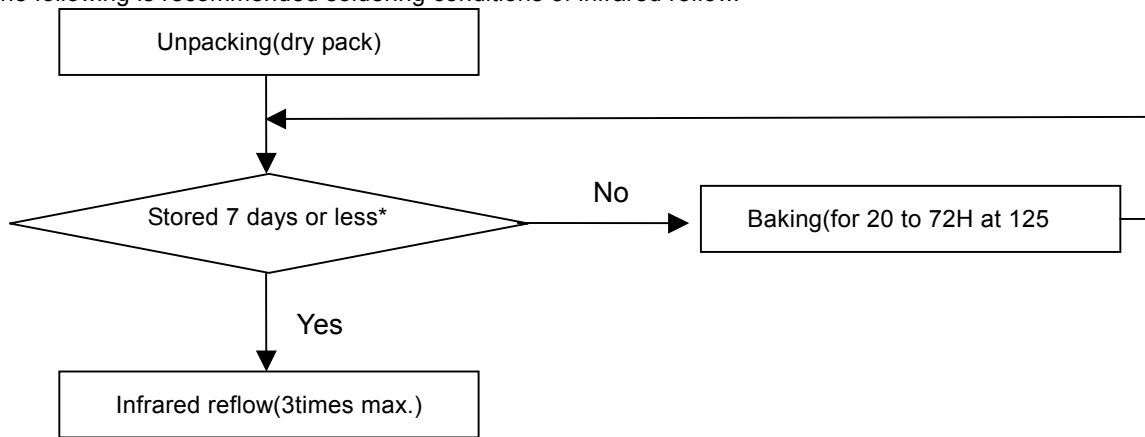

* - Storage conditions: Temperature 25 or less and humidity 65% or less

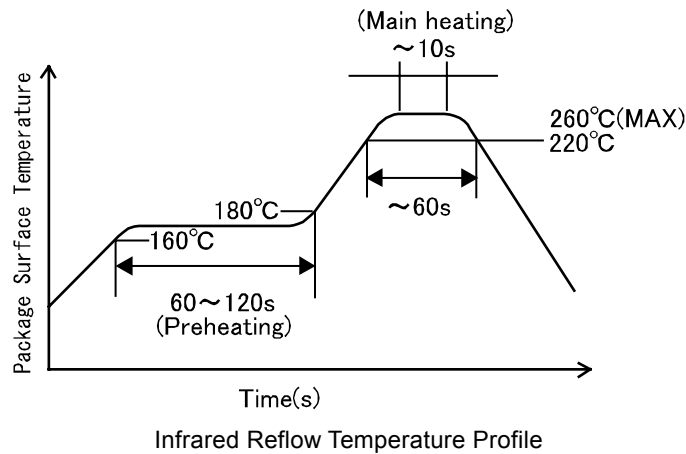

notice: For baking components, it is necessary to use heatproof type container. Plastic magazines, emboss tape/reels and some of trays are not heatproof type, so if the packing container is not heatproof type, please transfer them to a heatproof type container.

14. Reliability

Testing Report

Item	Test condition	Test Result ("S.S" is the number of sample. "***h" is the number of abnormal sample after passing of regulation time. Only number is the number of abnormal sample after end of test.)
(1)High Temperature/Humidity Operating Test(HHBT)	Ta=85 ,RH=85%,VDD=5.5V	S.S 168h 1000h 24 0 0
(2)Pressure Cooker Test(PCT)	Ta=125 ,RH=100%,2.3atm	S.S 96h 192h 20 0 0
(3)Temperature Cycling Test(T/C)	Ta=-65 ~ +150 ,各 30minutes	S.S 100h 300h 25 0 0
(4)High Temperature Operating Test(BT)	Ta=125 ,VDD=5.5V	S.S 168h 1000h 24 0 0
(5) High Temperature Storage Test(HT)	Ta=150	S.S 168h 1000h 20 0 0
(6)Thermal Test	Dip Soldering Lead 260 ,10sec, Non Flux, Temp.cycle 10cyc,Ta=65 ~ +150 ,every 30 minutes, Heat Shock15cyc,Ta=0 ~ +100	S.S 18 0
(7)Lead Bend Strength Test	250 g(Flat 125 g) 3 times bend	S.S 24 0
(8)Soldering Test	230 ,5sec Rosin Flux	S.S 24 0

This Test Data are typical data of the product (the same design rule) and the same package product.

Judgment Standard

- (1) ~ (6)→Being quality "good" by the electric measurement
- (7)→Non break/slack
- (8)→Soldering area is more than 95%

Static electric breakdown test result

Test condition	Standard Terminal	Polarity	Limit
EIAJ spec C=200pF,Rs=0Ω 5times add 5 samples	VDD	+	More than 250V
		-	More than 250V
	VSS	+	More than 250V
		-	More than 250V
MIL spec C=100pF,Rs=1.5kΩ 5times add 5 samples	VDD	+	More than 2000V
		-	More than 2000V
	VSS	+	More than 2000V
		-	More than 2000V

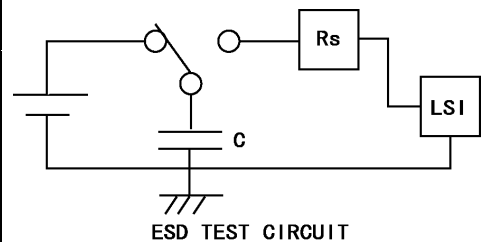

Latch up test result

Test condition	Standard Terminal	Limit
DC current injection VDD=VDDmax Ta = 25	VDD	More than 150mA(plus)
	VSS	Less than 150mA(minus)

notice)Reliability test data is limit test basis on reliability test. This test data doesn't warranty about movement and indication dignity.

Contents are a report by an IC production maker.

15. Packing Condition

When Storage Conditions is extremely bad, there is danger that soldering performance fall and appearance is defective, characteristic deterioration. Please be careful.

We recommend below condition about storage.

- <1> Temperature: 5 ~ 30
 - <2> Humidity: less than 70%(RH)
 - <3> Ambient atmosphere: There is not harmful gas such as sulfurous acid gas and a little dust.
 - <4> Other: Not being accompanied as such as the vibration, the shock that a packing container transforms.
- In addition, please be careful to load by accumulation.

16. Packing Method

(1) Package Materials

Part Name
Tray
aluminum laminating bag
Outer Box

Packing Procedure

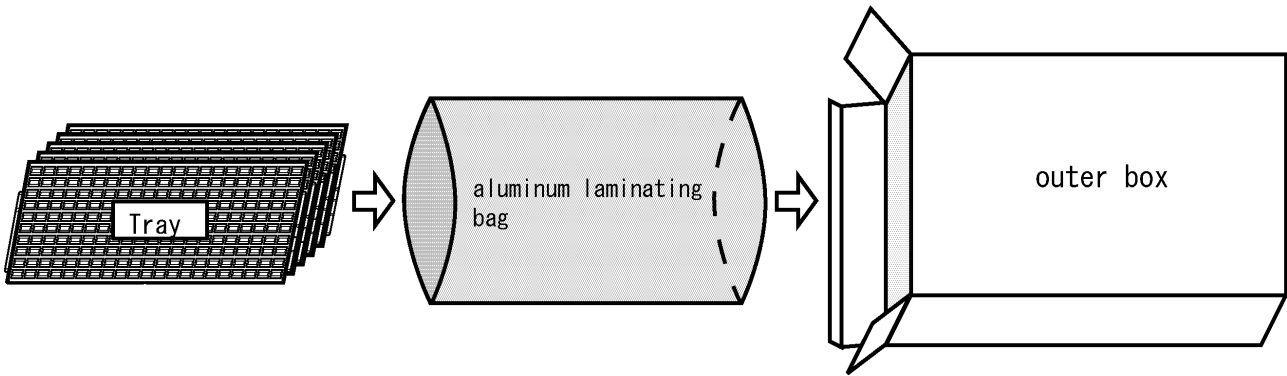

Max 5 tray per 1 aluminum laminating bag

Direction of IC Insertion

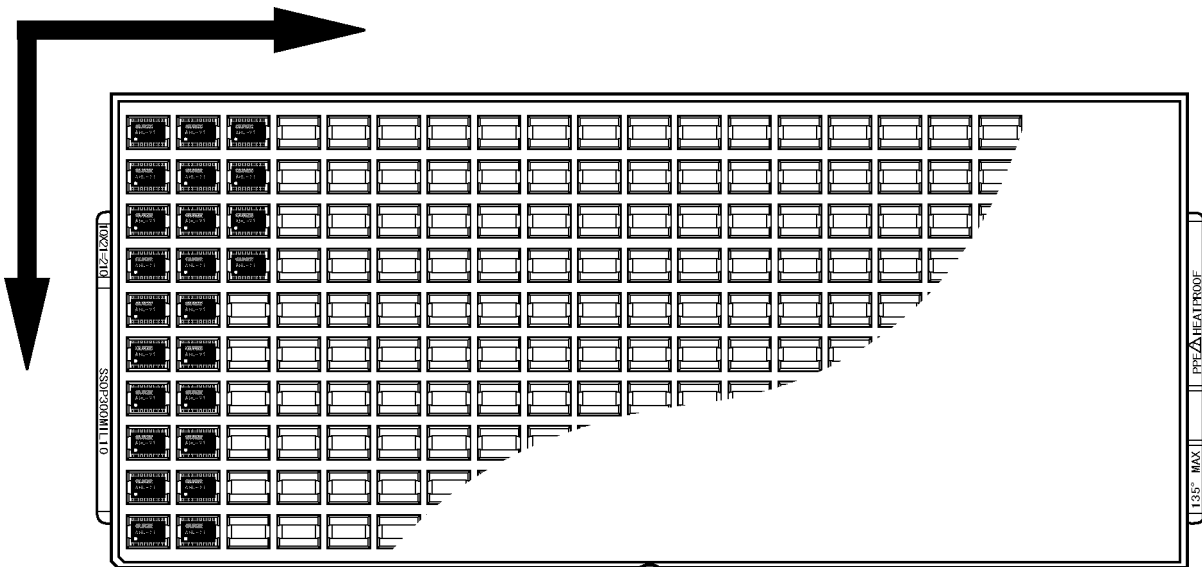

(2)When there is a little amount, we load the next line and can continue to the amount that it is necessary, then one line reaches ten.

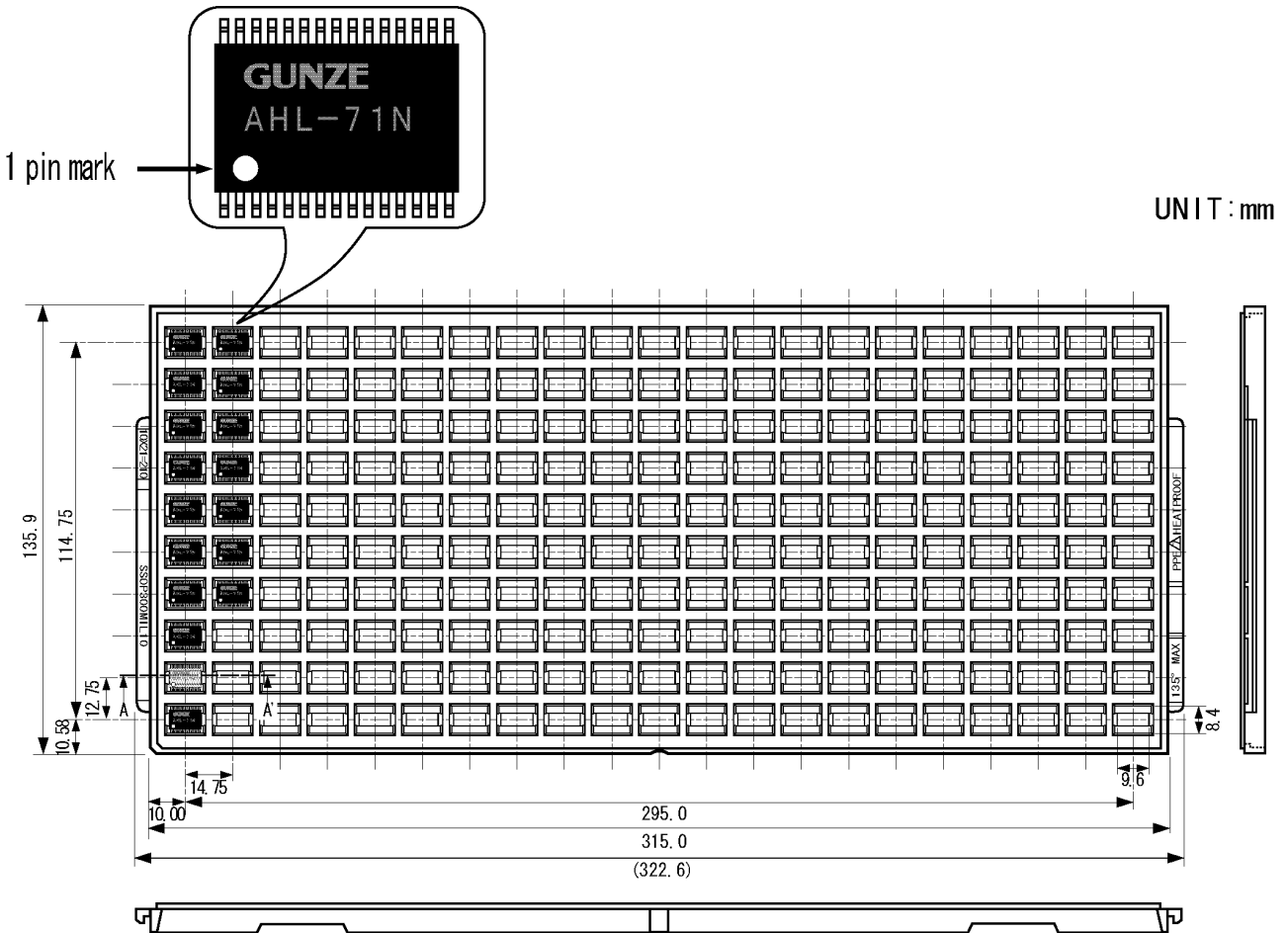

UNIT : mm

<SECTION A-A' >

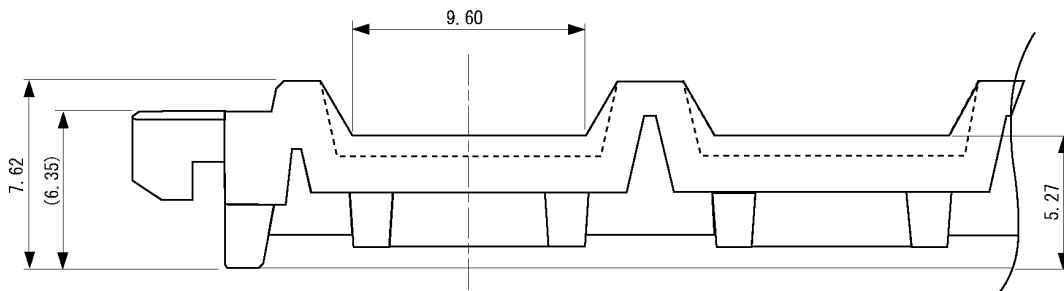

Applied Package	Quantity(pcs)
30pin Plastic Shrink SOP(1.2mm,1.7mm thick)	MAX 210

Tray	SSOP300MIL10
Material	Carbon PPE
Heat Proof Temp.	135
Surface resistance	Less than 1×10^{12} /

above dimension is maximum number of delivery every one tray. When there is a little amount, we can deliver products carry on cut tray.

The tolerance of tray's dimensions are based on JEDEC STANDARD.

(3) Packing Label

GUNZE GZ-Switch

TOUCH PANEL タッチパネル

MODEL NUMBER 品番			
LOT NO.			
QUANTITY 数量		SHIPPING DATE 出荷年月日	
REMARK 備考			
GUNZE LIMITED ELECTRONICS COMPONENT		グンゼ株式会社 電子部品事業部	

Article number : AHL-71N
LOt No. : not enter
Amount : ****
Shipment date : '05.1.1(2005/1/1)
Note : User Arrangement No. left-hand figure attaches to the top surface of packing box

17. Operating Precautions

- (1) The AHL-71N may produce a latch-up phenomenon where higher voltage than VDD and lower voltage than VSS were applied or voltage exceeding the rating was applied between VDD and VSS. If there arises this latch-up, supply current will significantly increase, leading to thermal breakdown of the element from time to time; it is, therefore, necessary to take utmost care so that the maximum rating is not exceeded during operation.
- (2) The operation guarantee range of VDD supply voltage is as specified. Even within this range, however, if there are sudden fluctuations in supply voltage, malfunctions may arise; it is, therefore, necessary to make arrangements so that supply voltage becomes as stable as possible. It is recommended that as a reference for stabilization, VDD ripple fluctuations (P-P value) at commercial frequency (50 to 60Hz) should be controlled to 10% Max. of the standard VDD value and the transient regulation should be controlled to 0.1 V/ms Max. in momentary changes, for example when the power supply is switched.
- (3) When designing the peripheral circuit, make the wiring from the touch panel to the AHL-71N as short as possible. Also, do not provide any parts and wiring that may generate noise near this line. Since this line is an analog line, the AHL-71N may misjudge touch panel ON/OFF and fail to detect the accurate pressing position when the touch panel was depressed if the wiring becomes longer and it is affected by noise.
- (4) Avoid using the unit in the environment such that there arises dew condensation.
- (5) When handling the AHL-71N, give special care to static electricity, and provide satisfactory grounding for the operator and work site; otherwise, the AHL-71N may be broken.
- (6) The use of this unit exceeding the specified operating voltage and operating temperature may cause failure. Always use the unit within the specifications.
- (7) Store the AHL-71N within the temperature and humidity prescribed in the specifications. Do not store the AHL-71N in the atmosphere of organic solvent and acid.

18. Warranty Period and Warranty Range

(1) Warranty period

The warranty period should be one (1) year after the date of delivery.

(2) Warranty range

In the warranty period, if there arises failure or damage due to our nonconformity, our company is ready to repair or replace the defectives. However, in the following cases, the defectives are excluded from the warranty range.

- (a) Failure and damage caused by your mishandling, such as fall and shocks during transportation (movement) after delivery
- (b) Failure and damage caused by disasters and accidents
- (c) Repair & remodeling at other than our company
- (d) Failure and damage caused by handling that runs counter to the usage and precautions described in this specification

NOTE) Only the delivered product should be guaranteed, and any damage induced due to delivered product failure, repair and replacement on work site should be out of the warranty range.

19. Appendix

■Difference between 4- and 8-wire touch panels

(a) 4-wire touch panel

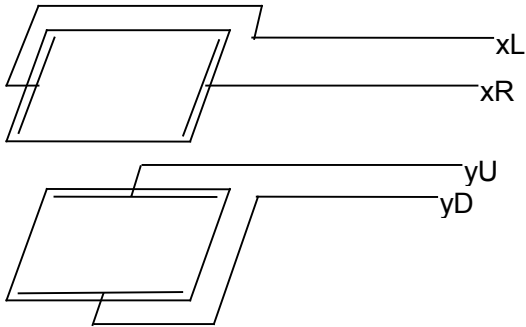

The analog voltage value (position data) in the pressing position is converted to the digital value as it is for output.

Example) When 5 V DC is applied to the touch panel and the analog voltage value in the pressing position is 2 V;

$$2(V) / 5(V) \times 1023 = 409$$

Thus, "409" is outputted.

(b) 8-wire touch panel

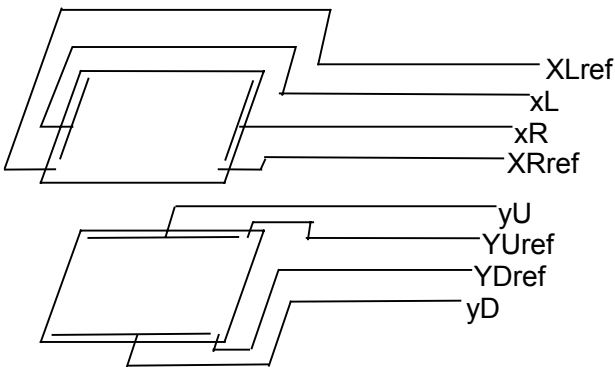

Read the touch panel reference voltage (xRref, xLref, yUref, yDref) and correct the analog voltage value in the pressing position (position data) so that xLref = 0, xRref = 1023, yDref = 0 and yUref = 1023 for output.

Example) When the analog voltage value in the pressing position is 2 V with 5 V DC applied to the touch panel and the reference voltage (for example, xLref, xRref) is 20 and 1,000 respectively: (10-bit resolution)

$$2(V) / 5(V) \times 1023 = 409$$

$$(409 - 20) / (1000 - 20) \times 1023 = 406$$

Thus, "406" is outputted.

* For details, refer to "10. Other function (1) Calibration (a) Auto calibration".